

KEC03S ABSOLUTE ENCODER

TECHNICAL SPECIFICATIONS

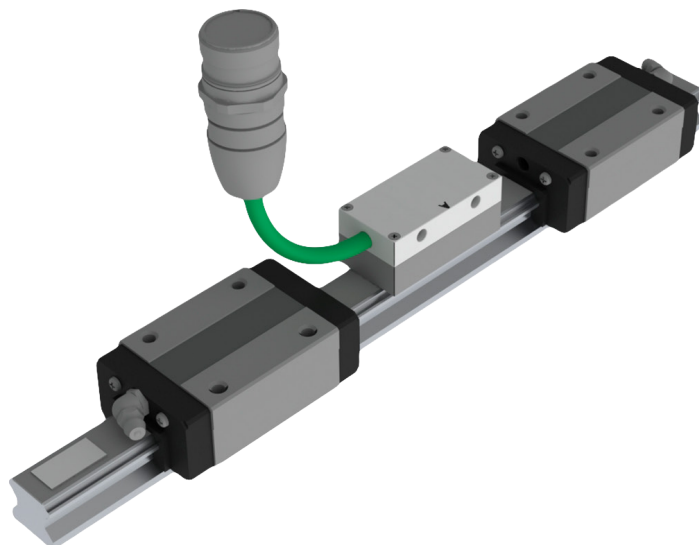

Inductive measuring systems

Inductive measuring systems are particularly suitable for applications with linear axes. Due to its inductive measuring system, this system offers great reliability and resistance to dust, oils, and even wood chips. The electromagnetic fields do not affect correct operation of the measuring system. The special properties of these measuring systems are therefore very suitable for use with direct drives and linear motors.

Magnetic measuring systems

Magnetic encoders provide excellent performance in dusty and contaminated environments. Due to the greater tolerance between encoder and measuring tape, this encoder is particularly suitable for long measurements.

	KEC03S - 3A	KEC03S - 5S
Measuring principle	Inductive	Magnetic
Maximum length	Up to 32 m	Up to 16 m
Resistance to dirt, oil, water, coolant and swarf	Very high	Very high
Resistance to electromagnetic interference and magnetic fields	Very high	Low
Repeatability of the measuring system	+/- 5 µm o +/- 10 µm	+/- 20 µm
Resolution of the measuring system	Until 100 nm	Until 1 µm
Reading head output / Measuring system	EnDat 2.2 EnDat 2.2 + Safety DriveCliq + Safety SSI + 1 Vss Fanuc Mitsubishi Biss/C	Hiperface Hiperface DSL

KEC03S - 3A ABSOLUTE ENCODER TECHNICAL SPECIFICATIONS

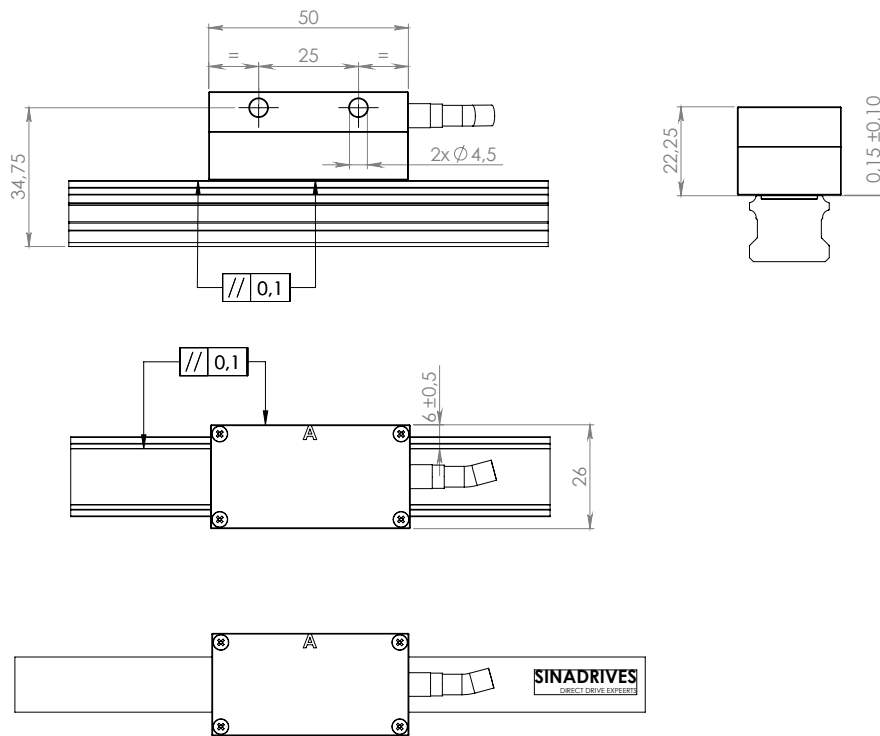

KEC03S - 5S ABSOLUTE ENCODER TECHNICAL SPECIFICATIONS

