

## KMC80S SERIES - IRON CORE LINEAR MOTOR

### DIMENSIONS AND SPECIFICATIONS

Magnet plate dimensions			
Code	KMM800192	KMM800288	KMM800384
Le (mm)	192	288	384
M5 bolts	8	12	16
Mass (kg/m)	34		
Magnet plates can be butted together.			

#### Water cooling

All KMC80S motors feature integrated cooling channels that allow for the easy setup of a liquid cooled system, at no additional cost.

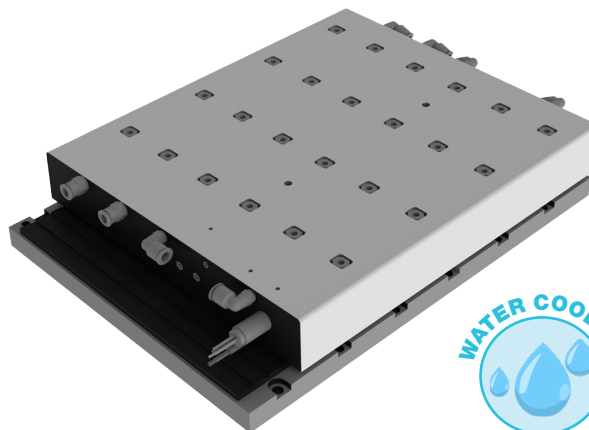

Parameter		Remarks	Sym	Unit	KMC80S						
Performance	Winding type				II34H	II42H	II50H	II67N	II84H	II12H	
	Motortype, max voltage ph-ph				3-phase synchronous Iron core, 380 V <sub>ac rms</sub> (600V <sub>dc</sub> )						
	Ultimate force @ 10°C/s increase	Magnet @ 25°C	F <sub>u</sub>	N	3360	4200	5040	6720	8400	12600	
	Peak force @ 6°C/s increase	Magnet @ 25°C	F <sub>p</sub>	N	3200	4000	4800	6400	8000	12000	
	Continuous force watercooled**	Coils @ 110°C	F <sub>cw</sub>	N	2080	2600	3120	4160	5200	7800	
	Continuous force aircooled*	Coils @ 110°C	F <sub>c</sub>	N	1600	2000	2400	3200	4000	6000	
	Maximum speed**	@ 600 V	V <sub>max</sub>	m/s	3.0						
Motor force constant	Mount. sfc. @ 20°C	K	N/A <sub>rms</sub>	174							
Motor constant	Coils @ 25°C	S	N <sup>2</sup> /W	1802	2243	2883	3604	4485	12615		
Electrical	Ultimate current	Magnet @ 25°C	I <sub>u</sub>	A <sub>rms</sub>	26	34	40	52	65	98	
	Peak current	Magnet @ 25°C	i <sub>p</sub>	A <sub>rms</sub>	21	27	32	43	53	80	
	Continuous current water cooled	Coils @ 110°C	I <sub>cw</sub>	A <sub>rms</sub>	12	15	18	24	30	45	
	Continuous current air cooled	Coils @ 110°C	I <sub>c</sub>	A <sub>rms</sub>	9.2	12	14	18,5	23	35	
	Back EMF Phase-Phase <sub>peak</sub>		B <sub>errf</sub>	V/m/s	142						
	Resistance per phase	Coils @ 25°C ex. cable	R <sub>ph</sub>	Ω	2.8	2.25	1.75	1.4	1.125	0.8	
	Induction per phase	l < 0.6 lp	I <sub>ph</sub>	mH	28	22.5	17.5	14	11.3	8	
Electrical time constant	Coils @ 25°C	T <sub>e</sub>	ms	10							
Thermal	Max. continuous power loss	All coils	P <sub>c</sub>	W	1847	2319	2597	3693	4638	6957	
	Thermal resistance	Coils to mount. sfc.	R <sub>th</sub>	°C/W	0.08	0.06	0.05	0.04	0.03	0.01	
	Watercooling flow	for ΔT=3K	Ow	l/min	4.1	5.2	6.2	8.2	10.4	15.5	
	Temperature cut-off / sensor				PTC 1kΩ / NTC						
Mechanical	Coil unit weight	ex. cables	W	kg	9	12	15	20	25	38	
	Coil unit length	ex. cables	L	mm	273	321	336	465	593	865	
	Motor attraction force	rms @ 0 A	F <sub>a</sub>	N	7200	9000	10800	14400	18000	27000	
	Magnet pitch NN		t	mm	24						
	Cable Type (power)	Length 3 m	d	mm (AWG)	10.1 (14)			12.1 (11)		14.7(9)	
	Cable Type (sensor)	Length 3 m	d	mm (AWG)	4,9 (26)						
	Cable Life	Minimum			5.000.000 cycles			3-5 millones cycles			
Bending Radius Static	Minimum			4x cable diameter			5x cable diameter				
Bending Radius Dynamic	Minimum			7,5x cable diameter			10x cable diameter				

\* These values are only applicable when the mounting surface is at 20°C and the motor is driven at maximum continuous current. If these values differ in your application, please check our simulation tool.

\*\* Actual values depend on bus voltage. Please check the F/v diagram in our simulation tool.

\*\*\* Depending on bending radius, velocity and acceleration.

# KMC80S SERIES - IRON CORE LINEAR MOTOR

## DIMENSIONS AND SPECIFICATIONS

### MAGNET PLATES

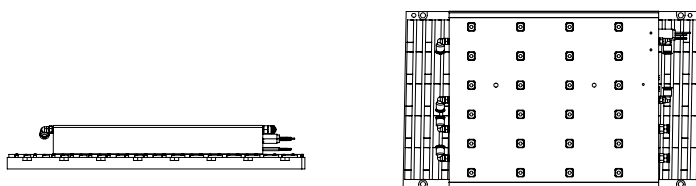
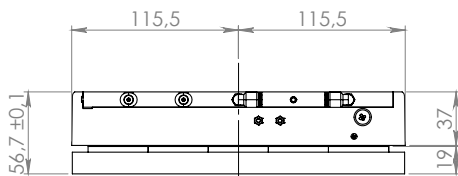

KMM800192

Slotted Hole  $\Phi 5 \times 0.5$  (3 deep)  
For Dowelpin DIN7  $\Phi 5h8$   
(Optional use)

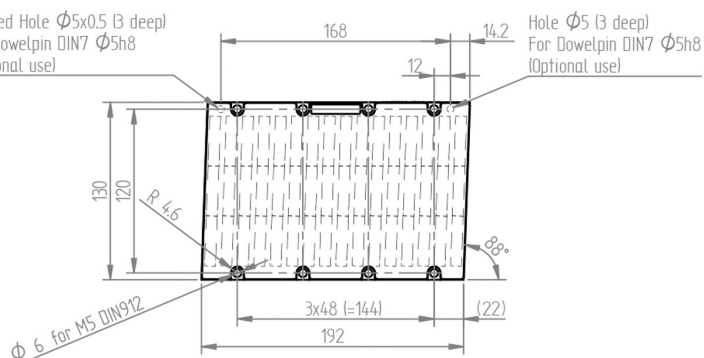

Hole  $\Phi 5$  (3 deep)  
For Dowelpin DIN7  $\Phi 5h8$   
(Optional use)

KMM800288

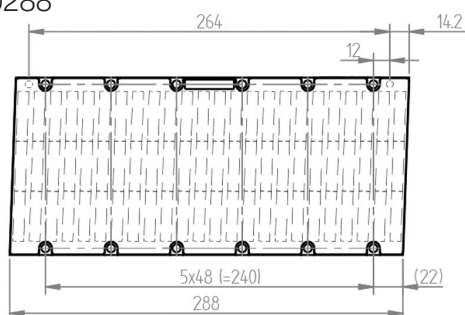

KMM800384

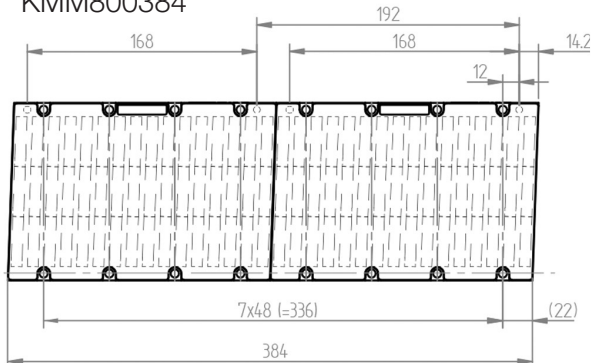

KMC80S-II34H

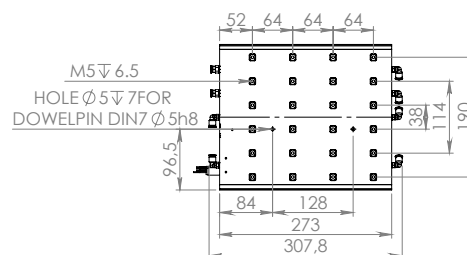

KMC80S-II42H

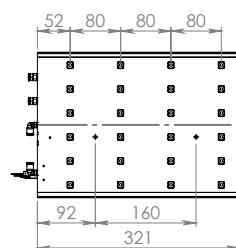

KMC80S-II50H

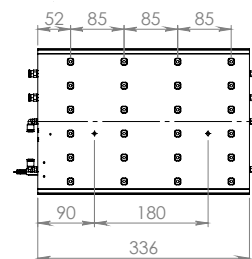

KMC80S-II67N

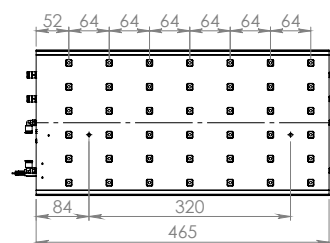

KMC80S-II84H

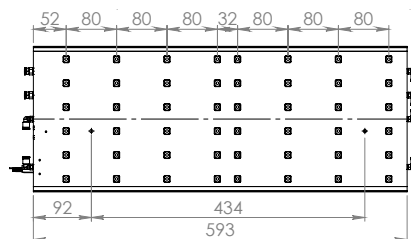

KMC80S-II13H

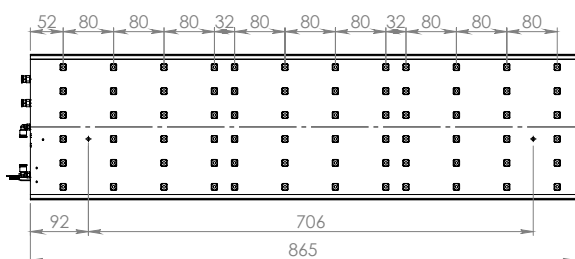

Mounting instructions and flatness or parallelism requirements can be found in the iron core installation manual. CAD files, 3D models and the manual can be downloaded from our website.

\* All sizes are in mm